

---

# INSTRUCTION MANUAL

---

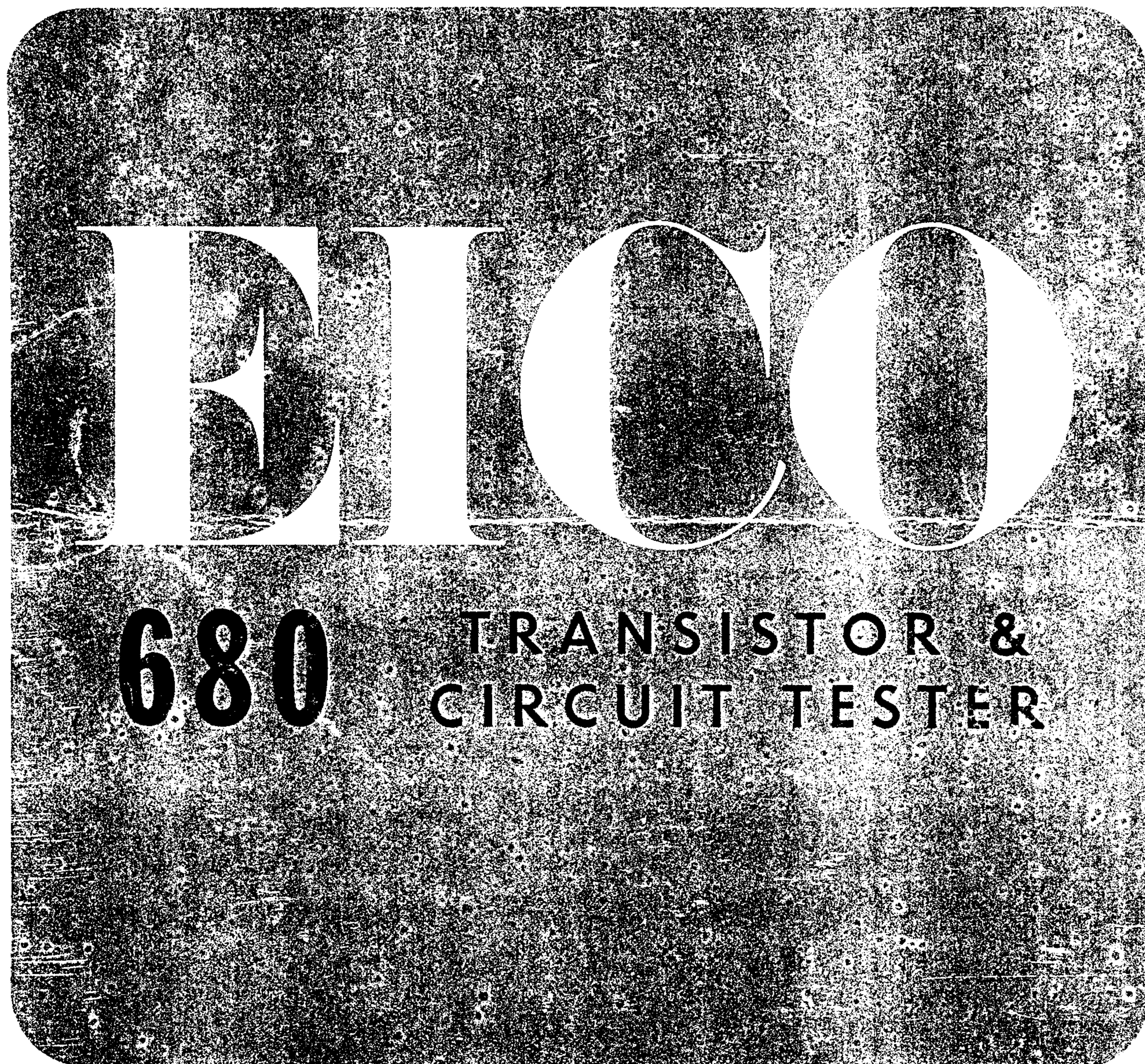

283 Malta Street, Brooklyn, N. Y. 11207



# TRANSISTOR & CIRCUIT TESTER

## TABLE OF CONTENTS

SECTION I. GENERAL DESCRIPTION AND SPECIFICATIONS	Page
1-1. General Description .....	2
1-2. Features .....	2
1-3. Specifications .....	2
SECTION II. OPERATING INSTRUCTIONS	
2-1. Voltage Measurement .....	2
2-2. Current Measurement .....	3
2-3. Resistance Measurements .....	3
2-4. Transistor Current Leakage Tests.....	3
2-4A. ICBO Test.....	3
2-4B. ICBO Test.....	4
2-5. DC Beta Test.....	4
2-6. Simulated AC Beta Test .....	4
2-7. Power Transistor DC Beta.....	5
2-8. Diode Test.....	5
SECTION III. CIRCUIT THEORY	
3-1. General.....	5
3-2. DC Voltmeter.....	5
3-3. DC Current Measurements.....	6
3-4. Resistance Measurements .....	6
3-5. ICBO Test Circuit .....	7
3-6. ICBO Test Circuit .....	7
3-7. Beta Tests .....	7
SECTION IV. TEST TECHNIQUES	
4-1. Meter Ranges .....	8
4-2. Leakage Tests.....	8
SECTION V. MAINTENANCE	
5-1. Battery Replacement.....	8
5-2. Service.....	8
SECTION VI. REPLACEMENT PARTS LIST.....	12

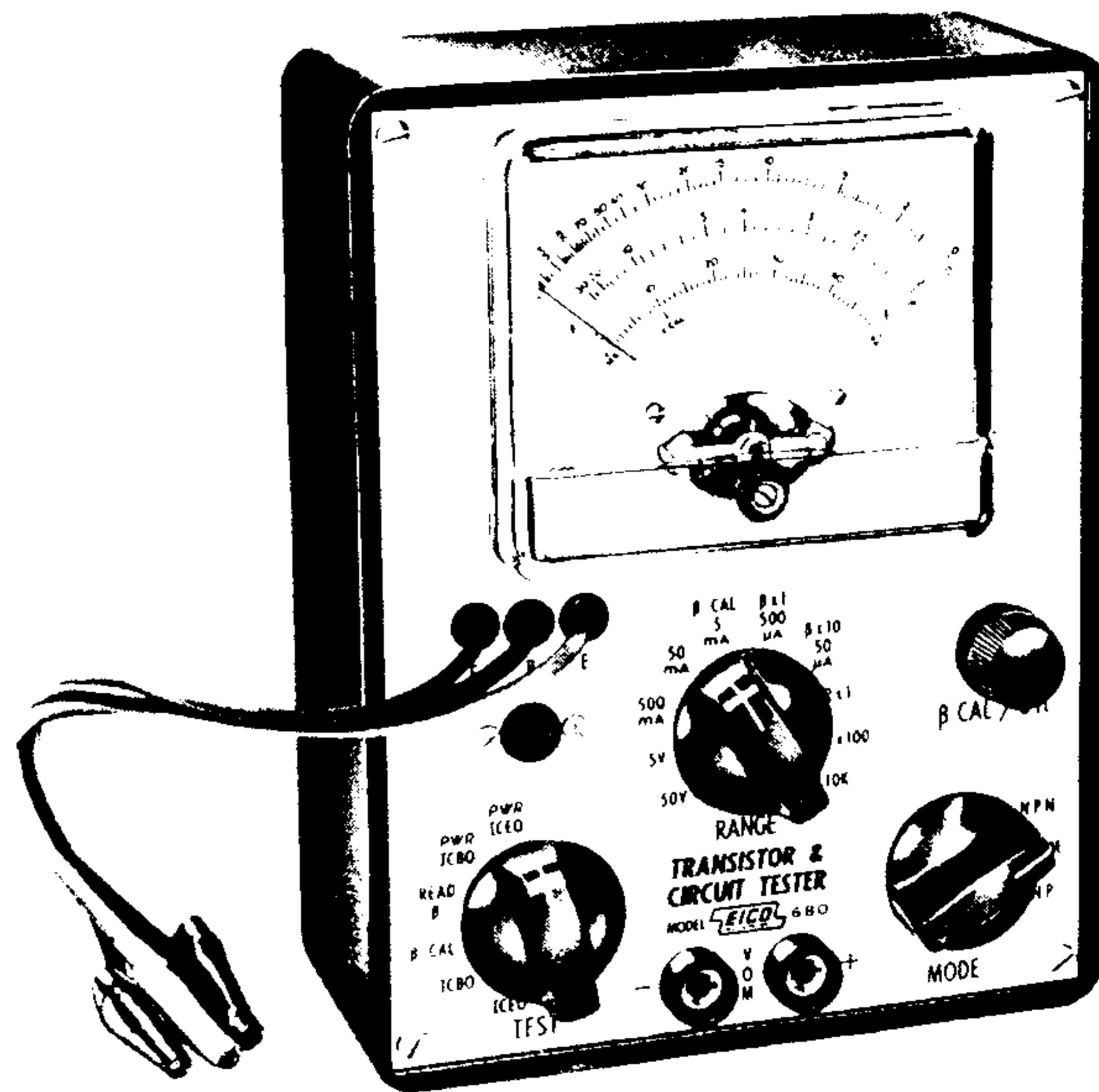

## FIGURES

SECTION I. GENERAL DESCRIPTION	Page
Photo. EICO Model 680 Transistor Checker.....	1
SECTION II. OPERATING INSTRUCTIONS	
Fig. 2-1. Graph AC $\beta$ vs. $I_{b2}-I_{b1}$ .....	4
Fig. 2-2. Cathode Identification of Diodes.....	5
SECTION III. CIRCUIT THEORY	
Fig. 3-1. Voltmeter Circuit .....	6
Fig. 3-2. Ammeter Circuit.....	6
Fig. 3-3a. Rx1 Circuit.....	6
Fig. 3-3b. RX100 Circuit.....	6
Fig. 3-3c. RX10K Circuit .....	6
Fig. 3-4. Ohmmeter Circuit.....	7
Fig. 3-5. ICBO Test Circuit.....	7
Fig. 3-6. ICBO Test Circuit.....	7
Fig. 3-7a. Actual Circuit Switching.....	8
Fig. 3-7b. Schematic of Circuit.....	8
SECTION V. MAINTENANCE	
Fig. 5-1. Battery Placement .....	9
Fig. 5-2. Switching Table for 680.....	10
Fig. 5-3. Schematic Diagram for 680.....	11



## SECTION I. GENERAL DESCRIPTION AND SPECIFICATIONS

### 1-1. GENERAL DESCRIPTION

The Model 680 Transistor and Circuit Tester provides accurate measurement of basic transistor and diode characteristics required for quality testing, plus the VOM facilities normally required for testing and trouble-shooting transistor circuits. Transistor measurements include ICBO and ICEO, with separate test positions for signal and power transistors, DC Beta, and simulated AC Beta. Simple criteria for all measurements are included in the instruction manual and no charts are used or needed. The VOM facilities include five DC current ranges down to 50uA full scale, two DC volts ranges at 20,000 ohm/volt, and three resistance ranges. The tester is self-powered by five inexpensive, standard batteries, and is housed in a sturdy bakelite case and brushed aluminum panel.

### 1-2. FEATURES

1. 50uA, 3-1/2" face D'Arsonval meter movement of 2% accuracy.
2. 1% meter multiplier and shunt resistors.
3. ICBO and ICEO are measured accurately on the microammeter ranges with sensitivity to 50 microamps full scale.
4. ICBO and ICEO measurements can be made on all types of transistors. Separate test positions are provided for signal and power transistors.
5. DC Beta for signal transistors given directly by reading base current on a reciprocal scale (multiplied by appropriate range factor) to establish standard 1ma collector current indexed on scale.
6. AC Beta for signal transistors determined by reading base current settings required to establish two standard collector currents 0.75 and 1.25ma indexed on the scale (500uA shift), and dividing 500 by the base current difference in uA, or referral to a chart in the manual which gives the result without calculation.
7. DC Beta for power transistors can be approximated by calculating ratio of ICEO to IBEO.
8. Quality of selenium rectifiers, germanium and silicon diodes determined by measurement of forward and reverse currents.
9. DC volts ranges are 20,000 ohms per volt, minimizing loading of the circuits under test.
10. Convenient MODE switch sets up instrument PNP transistors, NPN transistors, or VOM use.
11.  $\beta$  CAL/0 ohm (Beta calibrate or zero ohms) adjust not only provides essential control functions for operation of the instrument, but also prolongs the useful life of the internal batteries.

### 1-3. SPECIFICATIONS

DC Voltage Ranges: 0 to 5, 50 volts at 20,000 ohms per volt

DC Current Ranges: 0 to 50uA, 500uA, 5ma, 50ma, 500ma (0.1 volt drop across the meter).

Resistance Ranges: 0 to 2000 ohms, 12 ohm center scale, 0 to 200,000 ohms, 1200 ohm center scale, 0 to 20 Megohm, 120K center scale

Transistor Measurements: ICEO (signal transistors); ICBO (signal transistors); DC Beta (signal transistors) in 2 ranges - 2 to 30, 20 to 300; PWR ICBO (power transistors); PWR ICEO (power transistors). Each of the foregoing is read directly from the instrument scales at an individual test position. A simulated measurement of AC Beta (signal transistors) is also provided involving two sequential measurements.

Accuracy: 1% resistors and 2% meter movement

Connectors: Three clip-on test leads for connecting power transistors and socket for small signal units. Two banana jacks for VOM.

Controls: RANGE switch: See ranges above;  $\beta \times 1$ ,  $\beta \times 10$  correspond to 500uA, 50uA  
 MODE switch: NPN, VOM, PNP  
 TEST switch: ICEO, ICBO,  $\beta$  CAL, READ  
 $\beta$ , pwr ICBO, pwr ICEO  
 $\beta$  CAL/0 ohm: adjust control

Batteries: 4 size AA, 1 size C

Meter: 50uA movement, 3-1/2" face (clear plastic case)

Panel: Brushed aluminum, two-color deep-etched nomenclature

Case: Highly polished black bakelite

Size: 6-3/4 x 5-1/4 x 3 inches

Weight: 3 lbs.

## SECTION II. OPERATING INSTRUCTIONS

### 2-1. VOLTAGE MEASUREMENT

#### CAUTION

Never apply more than 50 volts across the leads connected to the VOM jacks.

1. Set the MODE switch to VOM.

2. Set the RANGE switch to the 50V range.

3. Connect the leads from the VOM jack across the voltage being measured, observing polarity. If you have been mistaken as to the polarity, the meter will read in the reverse direction. In this case, simply interchange the test leads.

4. Read the voltage on the black 0 to 50 scale. If it reads less than 5 volts, set the RANGE switch to 5V. In the latter case, divide the scale reading by 10 or read 0 to 5 on the 50 volt scale.



## 2-2. CURRENT MEASUREMENT

1. Set the MODE switch to VOM.
2. Set the RANGE switch to 500ma.

### CAUTION

Never place the instrument across a voltage source when it is set for current.

3. Connect the leads from the VOM jacks in series with the component through which the current flow is to be measured. Observe the current direction. If you have been mistaken as to the polarity, the meter will read in the reverse direction. In this case, simply interchange the test leads.

4. Read the current on the black 0 to 50 scale. To obtain the indicated current on this and the 500uA ranges, multiply the reading by 10. You read the scale directly in the 50ma and 50uA ranges. Divide the reading by 10 for the 5uA range.

5. If the reading is less than 50ma, on the 500ma range, switch to the 50ma range. If the reading is less than 5ma on this range, switch to the 5ma range. If the reading is less than 500uA (0.5ma) on this range, switch to the 500uA range. If the reading is less than 50uA on this range, switch to the 50uA range.

## 2-3. RESISTANCE MEASUREMENTS

1. Set the MODE switch to VOM.

2. Set the RANGE switch to the appropriate resistance setting. Thus, if the resistance is less than 150 ohms, use the Rx1 position. If it is between 150 and 15,000 ohms, use the Rx100 position. If it is above 15,000 ohms, use the Rx10K position.

3. Connect the leads from the VOM jacks to each other. Adjust the  $\beta$  CAL/0 ohm control so that the meter reads 0 on the top black scale marked " $\Omega$ ".

4. Disconnect the test leads from each other and connect them across the resistance to be measured. To obtain the resistance in ohms, read the ohms scale directly when the RANGE switch is in the Rx1 position, multiply by 100 when the RANGE switch is in the Rx100 position, and by 10,000 when the RANGE switch is in the Rx10K position.

## 2-4. TRANSISTOR CURRENT LEAKAGE TESTS

All transistors can arbitrarily be divided into two groups. One is the high power type, and the second is the low power or signal amplification type. We will arbitrarily consider any transistor that will fit into the socket on the panel as the signal type, and all others as the power types. The collector, base and emitter terminals of the power types should be connected to three leads identified by C, B, and E, respectively, on the panel, when they are being tested. The signal types should be inserted into the socket when they are being tested. If the leads on the signal types are too long to fit into the socket, or it is inconvenient to use the socket for any reason, these may also be connected to the C, B and E leads. The test procedure for the low power

or signal types will apply to these small signal transistors whether they are plugged into the socket or connected to the leads on the test instrument.

The socket is made so that the pin to be connected to the collector lead on the transistor is at the extreme left edge of the socket, nearest the lead marked C. The socket pin to be connected to the emitter lead is at the extreme right edge of the socket, nearest the lead marked E. The remaining two pins in the socket are for the base leads from the transistor, directly under the lead marked B.

Signal transistor leads are arranged in two forms, depending upon the type of transistor and the manufacturer. In one, the "in-line" arrangement, all leads form a straight line. The base lead is at the center. Of the remaining two leads, the one closest to the base is the emitter lead. The remaining one is the collector lead. In the second lead arrangement, the leads are arranged in a semicircle, one at each end and one in the middle of arc. The lead in the middle of the arc is the base. Hold a transistor with this lead arrangement over the socket in the panel, all leads pointing to the socket, and the base lead emerging closest to B. The lead at the extreme left is the collector and the lead at the extreme right is the emitter. The transistor leads may be inserted into the socket pins in this sequence. This time, the base lead is inserted into the upper, rather than the center base pin.

All transistors, whether they be of the signal or power types, can be divided into two structural groups. One is known as the PNP and the second as NPN.

Preliminary to performing any test on the transistor, determine if it is a PNP or NPN\*. When this is determined, set the MODE switch to either PNP or NPN, whichever applies. If the MODE switch is set incorrectly, the application of the test voltages in the wrong polarity will result in apparently very high "leakage" currents.

The leakage tests should always be performed before the  $\beta$  test. If a transistor proves defective in any leakage test, do not proceed to the  $\beta$  test.

In all tests set the meter first to the highest current range, and proceed to the lower ranges only after you are certain that the meter will not go off scale. After any test, and before switching the TEST control, always reset the RANGE switch to 500ma.

\*We strongly recommend that you obtain a comprehensive transistor substitution manual such as the "Transistor Substitution Handbook", Howard W. Sams publisher, Indianapolis 6, Indiana (Price \$1.50).

### 2-4A. ICEO TEST

1. Set the RANGE switch to 500ma.
2. Set the TEST switch to ICEO. (Use the pwr ICEO position if it is a power transistor as described above).
3. Plug the transistor under test into the socket or connect it to the appropriate three test leads marked C, B and E.
4. Read the leakage current on the appropriate scale as described in section 2-2, steps 4 and 5.



5. A good signal transistor will never read more than 1 milliamp and a good power transistor will never read more than 150 milliamps.

NOTE: ICEO varies with temperature. This reading may vary while the transistor is under test because of the temperature rise while the test current passes through the transistor.

#### 2-4B. ICBO TEST

1. Set the RANGE switch to 500ma.
2. Set the TEST switch to ICBO. (Use the pwr ICBO position if it is a power transistor as described above).

3. Plug the transistor under test into the socket or connect it to the appropriate three test leads marked C, B and E.

4. Read the leakage current on the appropriate scale as described in section 2-2, steps 4 and 5.

5. A good signal transistor will never read more than 20 microamps and a good power transistor will never read more than 300 microamps. In either case, this reading will be less than the ICEO reading for the same transistor if the transistor is not defective.

#### 2-5. DC BETA TEST

This test can be performed on signal type transistors only.

1. Set the TEST switch to  $\beta$  CAL.
2. Set the RANGE switch to  $\beta$  CAL.
3. Plug the signal transistor under test into the socket or connect it to the appropriate three test leads marked C, B and E.
4. Adjust the  $\beta$  CAL/0 ohm control so that the meter reads the longest of the three red lines, marked  $\beta$  CAL. If you cannot adjust the control for this reading on the meter, the transistor is probably too leaky and is therefore defective.

5. Set the TEST switch to READ  $\beta$ .

6. Set the RANGE switch to  $\beta$  x1 and read the Beta of the transistor directly on the red  $\beta$  scale. If the Beta is more than 20, switch to the  $\beta$  x10 range. Multiply the Beta reading by 10 in this range.

NOTE:  $\beta$  varies with the conditions of the test. This test is made at  $I_C = 1\text{ma}$ ,  $V_C = 4.7\text{V}$ . The readings made here can vary considerably from published specifications if the manufacturer's data is stated under different conditions.

#### 2-6. SIMULATED AC BETA TEST

This test can be performed on signal type transistors only. This is a simulated AC Beta test for it compares two static DC conditions. In essence, the transistor base current is adjusted with the  $\beta$  CAL/0 ohm control to establish two specific collector currents,

1.25ma and .75ma. The two base currents necessary to establish these two collector currents are measured. The ratio of the difference of the collector currents ( $1.25 - .75 = .50\text{ma} = 500\mu\text{A}$ ) to the difference of the respective base currents is the AC Beta. Note that there are three  $\beta$  CAL lines on the meter. The longest line at the center is used only in the DC Beta test above. The shorter two lines are used here in the simulated AC Beta test. The first of the shorter lines is the 0.75ma setting, and the other shorter line is the 1.25ma setting, both referred to above.

1. Set the RANGE switch to  $\beta$  CAL.

2. Set the TEST switch to  $\beta$  CAL.

3. Plug the signal transistor under test into the socket or connect it to the appropriate three test leads marked C, B and E.

4. Adjust the  $\beta$  CAL/0 ohm control so that the meter reads on the upper of the two short  $\beta$  CAL lines. If you cannot adjust the control for this reading on the meter, the transistor is probably too leaky, and is therefore defective.

5. Set the TEST switch to READ  $\beta$ . Turn the RANGE switch to a position where you can read the current accurately (500 $\mu\text{A}$  or 50 $\mu\text{A}$  range). Write down this reading, in microamperes. Let us refer to this point as  $I_{b2}$ .

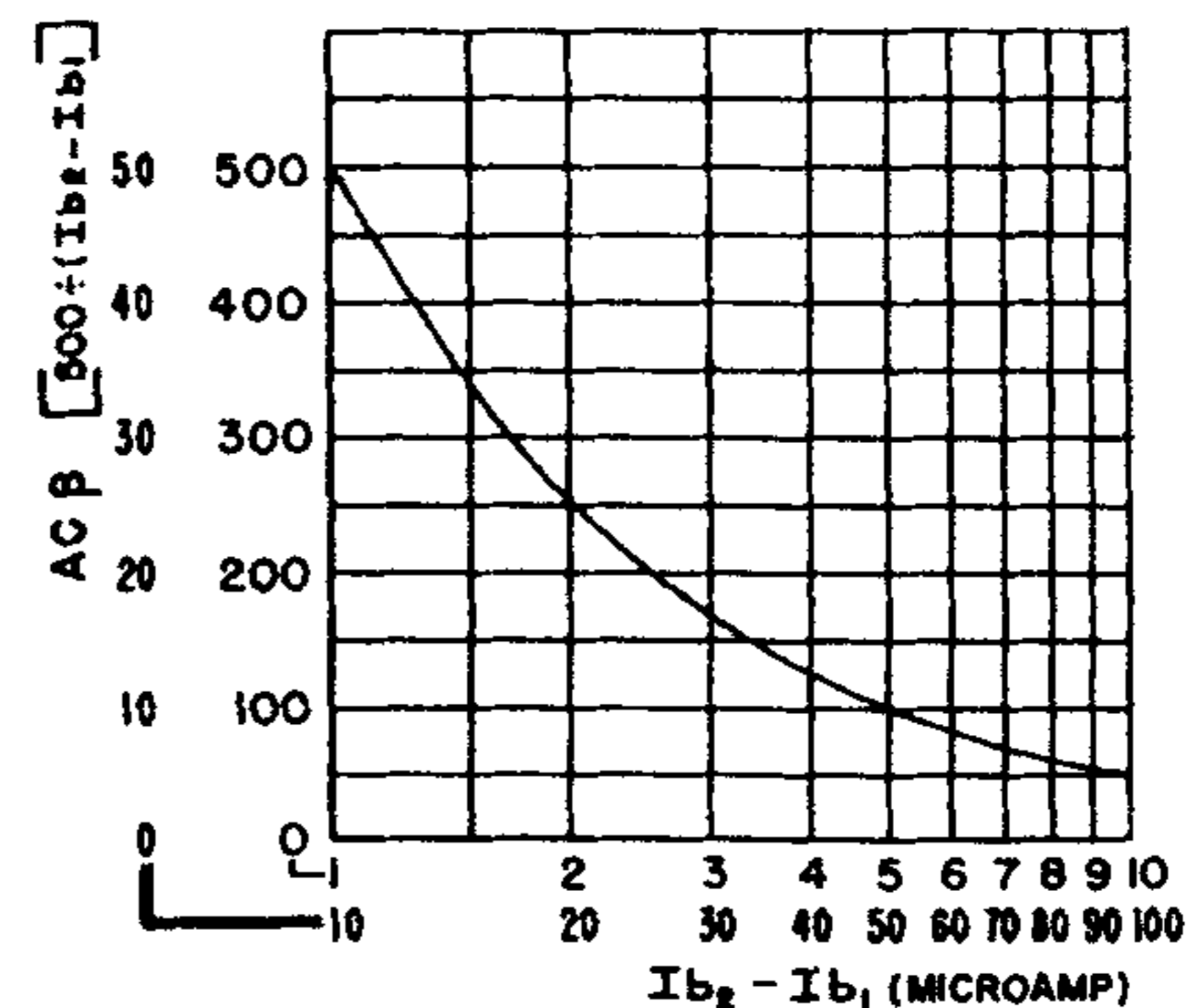

Figure 2-1. Graph AC  $\beta$  vs.  $I_{b2} - I_{b1}$ .

6. Reset the RANGE switch to  $\beta$  CAL.

7. Reset the TEST switch to  $\beta$  CAL.

8. Adjust the  $\beta$  CAL/0 ohm control so that the meter reads on the first of the two short  $\beta$  CAL lines. If you cannot adjust the control for this reading on the meter, the transistor is probably too leaky, and is therefore defective.

9. Set the TEST switch to READ  $\beta$ . Turn the RANGE switch to a position where you can read the current accurately (500 $\mu\text{A}$  or 50 $\mu\text{A}$  range). Write down this reading in microamperes. Let us refer to this point as  $I_{b1}$ .

10. Now subtract the  $I_{b1}$  reading taken in step 9 from the  $I_{b2}$  reading taken in step 5 ( $I_{b2} - I_{b1}$ ). Divide 500 by ( $I_{b2} - I_{b1}$ ). The formula is then:



$$AC\beta = \frac{500}{I_{b2} - I_{b1}}$$

This is the AC Beta of the transistor. A graph of this equation, giving values of  $AC\beta$  corresponding to values of  $(I_{b2} - I_b)$  from 1 to 100 in two ranges, is shown in Figure 2-1.

NOTE:  $\beta$  varies widely with the conditions of the test. This test is made in the vicinity of  $I_C = 1\text{ma}$ ,  $V_C = 4.7\text{V}$ . The readings made here can vary considerably from published specifications if the manufacturer's data is stated under different conditions.

## 2-7. POWER TRANSISTOR DC BETA

The direct DC Beta test described in section 2-5 is for signal transistors only and can not be used for power transistors. However, an indication of power transistor DC Beta can be derived from the ICEO and ICBO measurements. This is based on the fact that the DC Beta is related to ICEO and ICBO as follows:

$$\frac{ICEO}{ICBO} = \beta + 1$$

Since it may be assumed that Beta is much greater than unity, it is valid and reasonable to take Beta as being approximately equal to the ratio of ICEO to ICBO. Keep in mind that this is only a rough indication of the Beta, not the absolute value. The procedure is as follows:

1. Measure the ICEO as per section 2-4A, using the PWR ICEO test position.
2. Measure the ICBO as per section 2-4B, using the PWR ICBO test position.
3. Determine DC  $\beta$  by dividing the ICEO reading in microamps by the ICBO reading in microamps. Again, bear in mind that this is a rough indication of DC Beta, not the absolute value.

## 2-8. DIODE TEST

The quality of a diode is determined by the ratio of the forward to the reverse current. The ratio for good selenium rectifiers should be better than 10:1. The ratio for good germanium diodes is about 100:1. The ratio for good silicon diodes is better than 500:1. In general, good large single-cell selenium rectifiers will have a forward current of more than 125ma and a reverse current of less than 12ma. Good small multiple-cell selenium rectifiers (less than 100ma) will have a forward current of more than 1ma and a reverse current of less than 100uA. Good germanium diodes will have a forward current of more than 20ma and a reverse current below 100uA. Good silicon diodes will usually have a forward current of more than 50ma and a reverse current of less than 5uA.

However, more important than these values are

the forward to reverse ratios, although the absolute values may be used as a guide.

Diode forward and reverse current will vary with the applied voltage, and the readings will therefore depend on the condition of the internal batteries used in the tests. Their condition is satisfactory for the value criteria given above if it is possible to make the zero adjustment on the Rx10K ohmmeter range (see section 2-3). Diode characteristics also vary with temperature. The information given is for a diode under average room temperature conditions (about 70°F.) This test will determine only if there is diode action and will not indicate if it will withstand its rated voltage.

### CAUTION

Do not check diodes with the PIV rated at less than 5 volts, for they might break down. This precludes testing of most meter rectifiers.

1. Set the RANGE switch to 500ma.
2. Set the TEST switch to PWR ICEO.
3. Set the MODE switch to NPN.
4. Connect the anode terminal of the diode to the red lead marked "C" and the cathode terminal of the diode to the yellow lead marked "E". (See Figure 2-2 for diode lead arrangements. If the diode is marked with a +, this is the cathode terminal). Reset the range switch to read the current on the meter. (See section 3-3). This is the forward current.

### DIODES

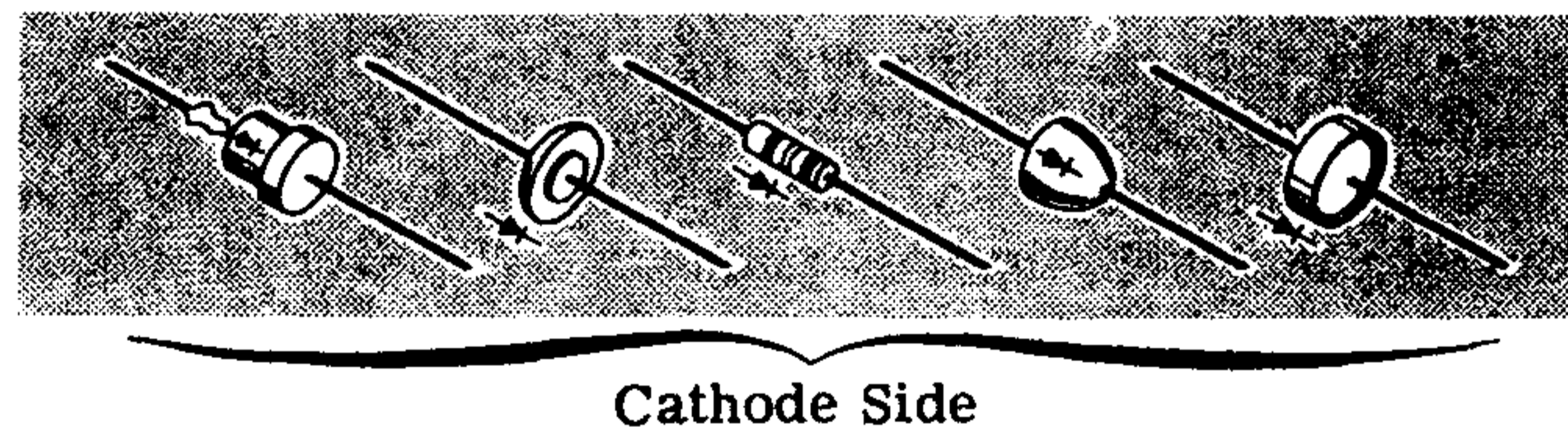

Figure 2-2. Cathode Identification of Diodes

5. Set the MODE switch to PNP. Reset the range switch to read the current on the meter. (See Section 3-3). This is the reverse current.
6. Remove the diode immediately after test to keep the battery current drain to a minimum.

## SECTION III. CIRCUIT THEORY

### 3-1. GENERAL

The theory of operation of each of the measuring circuits will be described below. Simplified individual schematic diagrams accompany each circuit description.

### 3-2. DC VOLTMETER

A voltmeter consists of a resistor in series with the meter movement. The meter is fully deflected by 50 microamperes. The resistor in series with the



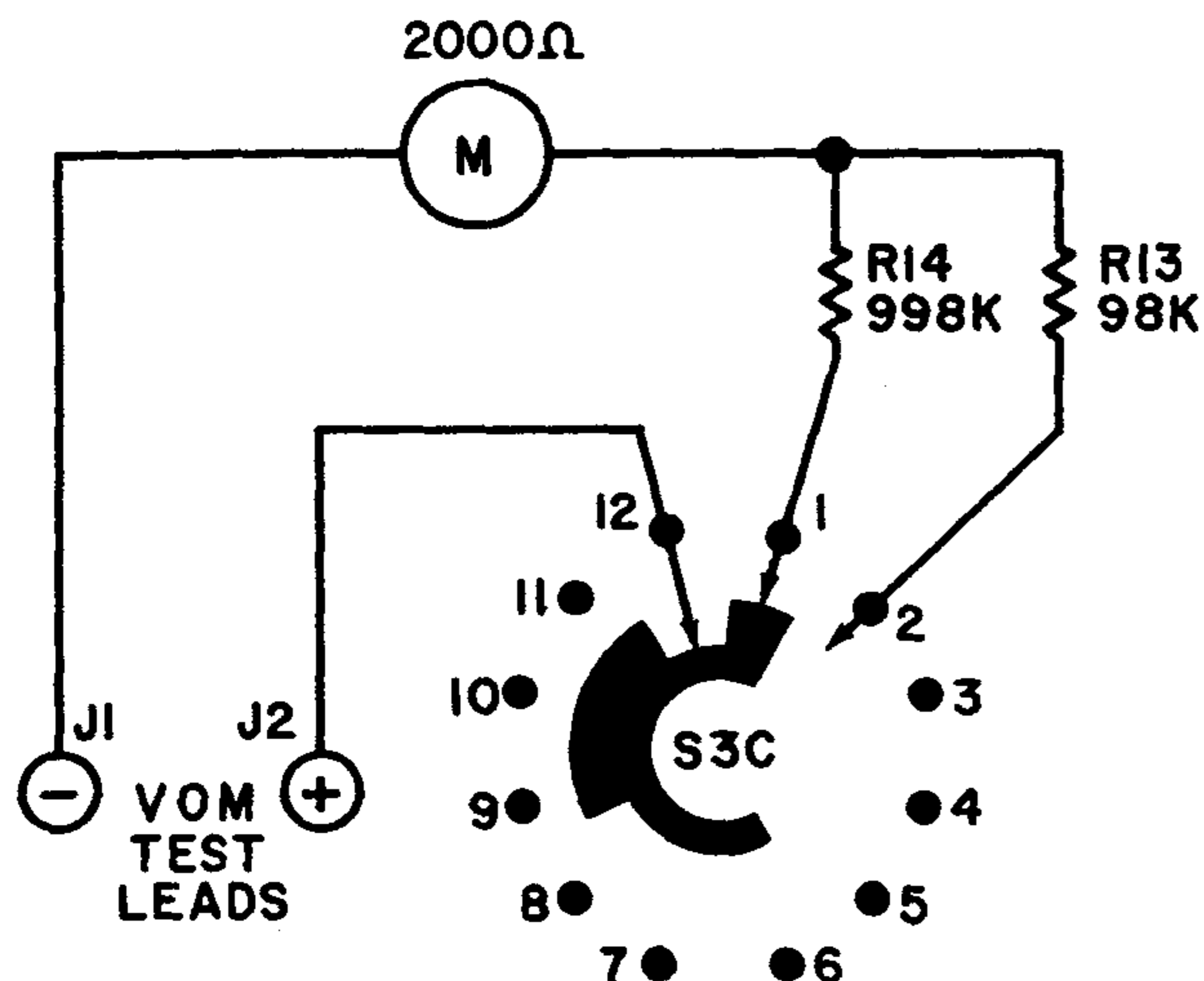

Figure 3-1. Voltmeter Circuit

meter limits the current so that 50 microamperes will pass through the meter only when 50 volts is applied across the series combination in one setting of the range switch and when 5 volts is applied across the series combination in the second setting of the range switch. As shown in Figure 3-1, in the former case 998K ohms is in series with the 2000 ohm meter and in the latter case 98K ohms is in series with the meter.

3-3. DC CURRENT MEASUREMENTS

Fifty microamperes flowing through the meter deflects the pointer full scale. To measure higher current with this meter, shunts must be provided to divide the current flow so that at full scale no more than 50 microamps passes through the meter. The meter is therefore shunted by appropriate resistors for each current range. To increase the range 10 times to 500 microamperes, 450 microamperes must pass through the shunting resistors and 50 microamperes through the meter movement. A shunt of 222.2 ohms is thus placed across the 2000 ohm meter to divert 9/10 of the current. Lower shunting resistors are used on the higher ranges as shown in Figure 3-2. No shunt is used in the 50 microampere position of the switch.

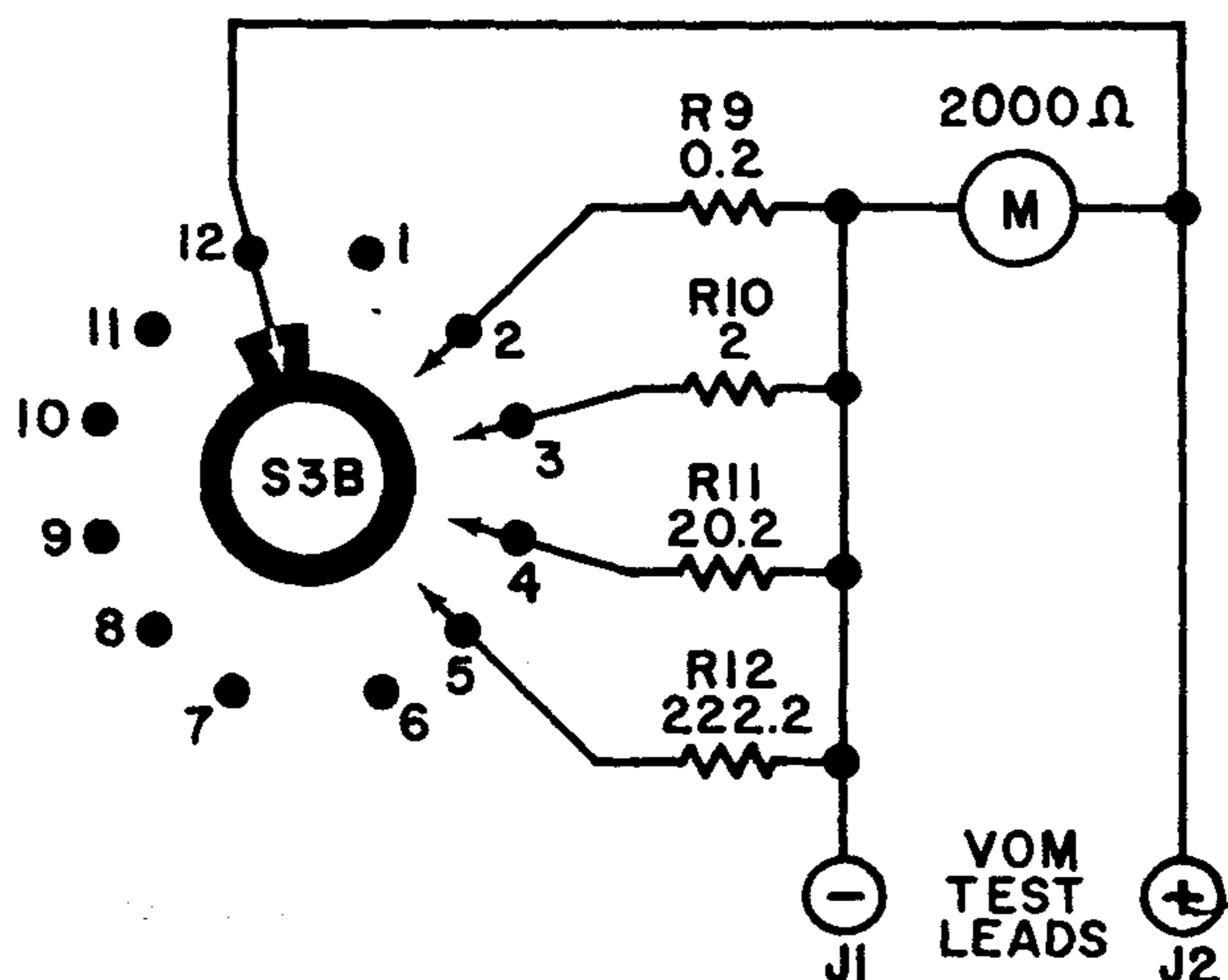

Figure 3-2. Ammeter Circuit

Four shunts are used in the other four ranges: 0.2 ohms for the 500ma range; 2 ohms for the 50ma range; 20.2 ohms for the 5ma range; and 222.2 ohms for the 500 microampere range. This section of the switch illustrates the selection of the shunt.

3-4. RESISTANCE MEASUREMENTS

The unknown resistor is connected at the meter test leads. The meter is arranged in circuits (wafer S3B) with different series and shunt resistors, to choose the desired range. The battery voltage is selected by switch section S3D. In each range, the 10K pot. adjusts the zero ohms reading, compensating for the increasing battery internal resistance with use.

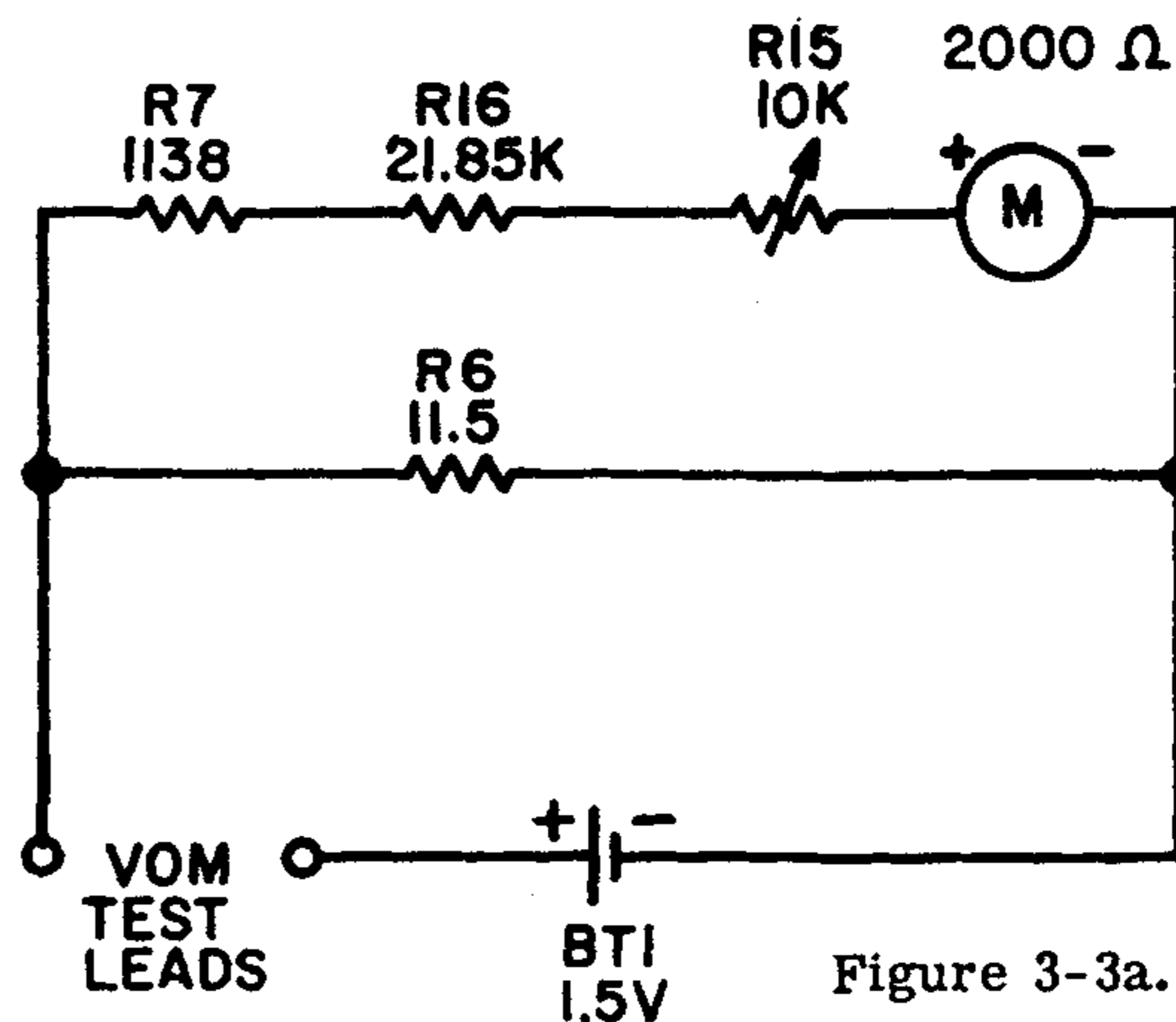

Figure 3-3a. (Rx1)

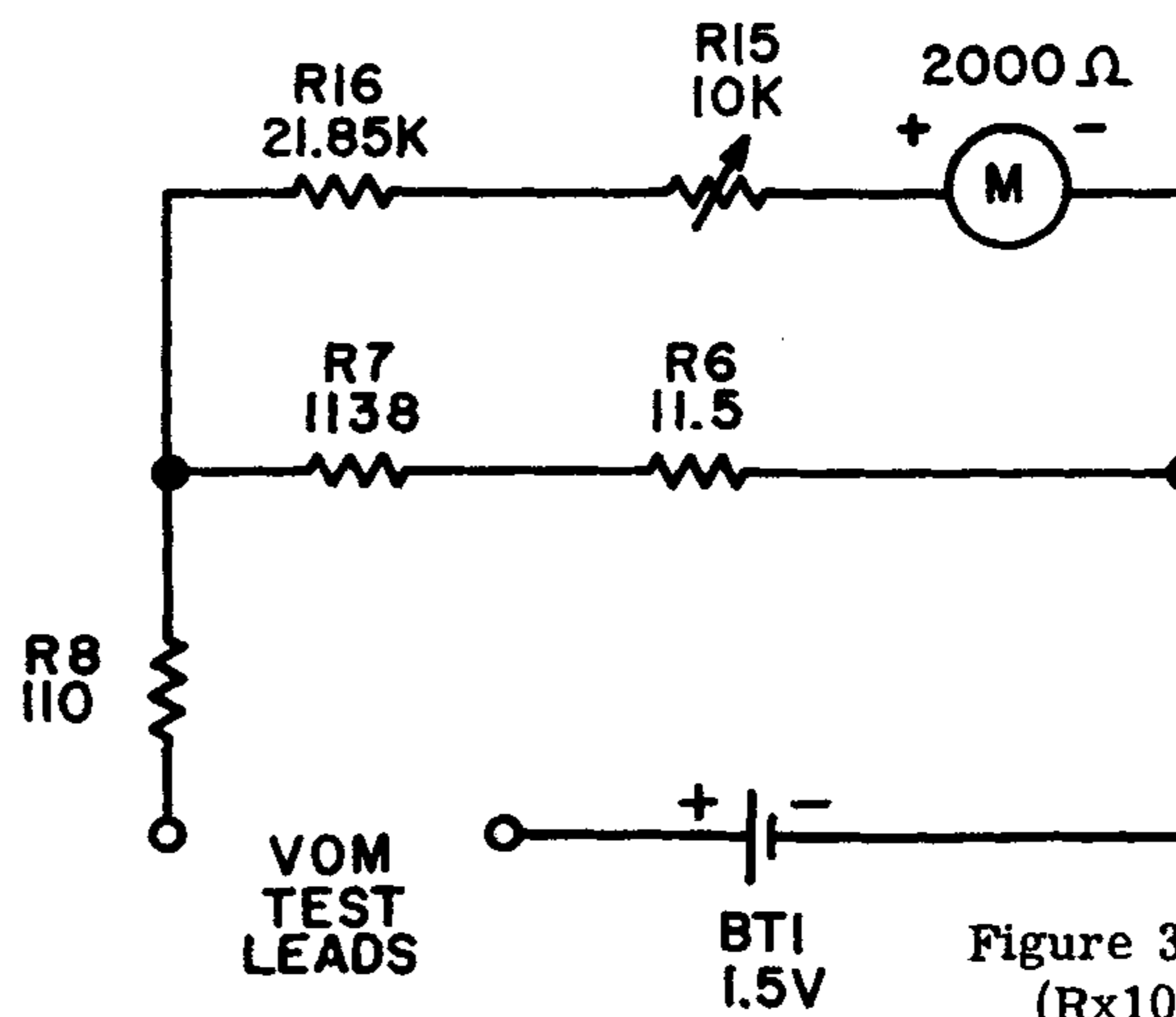

Figure 3-3b. (Rx100)

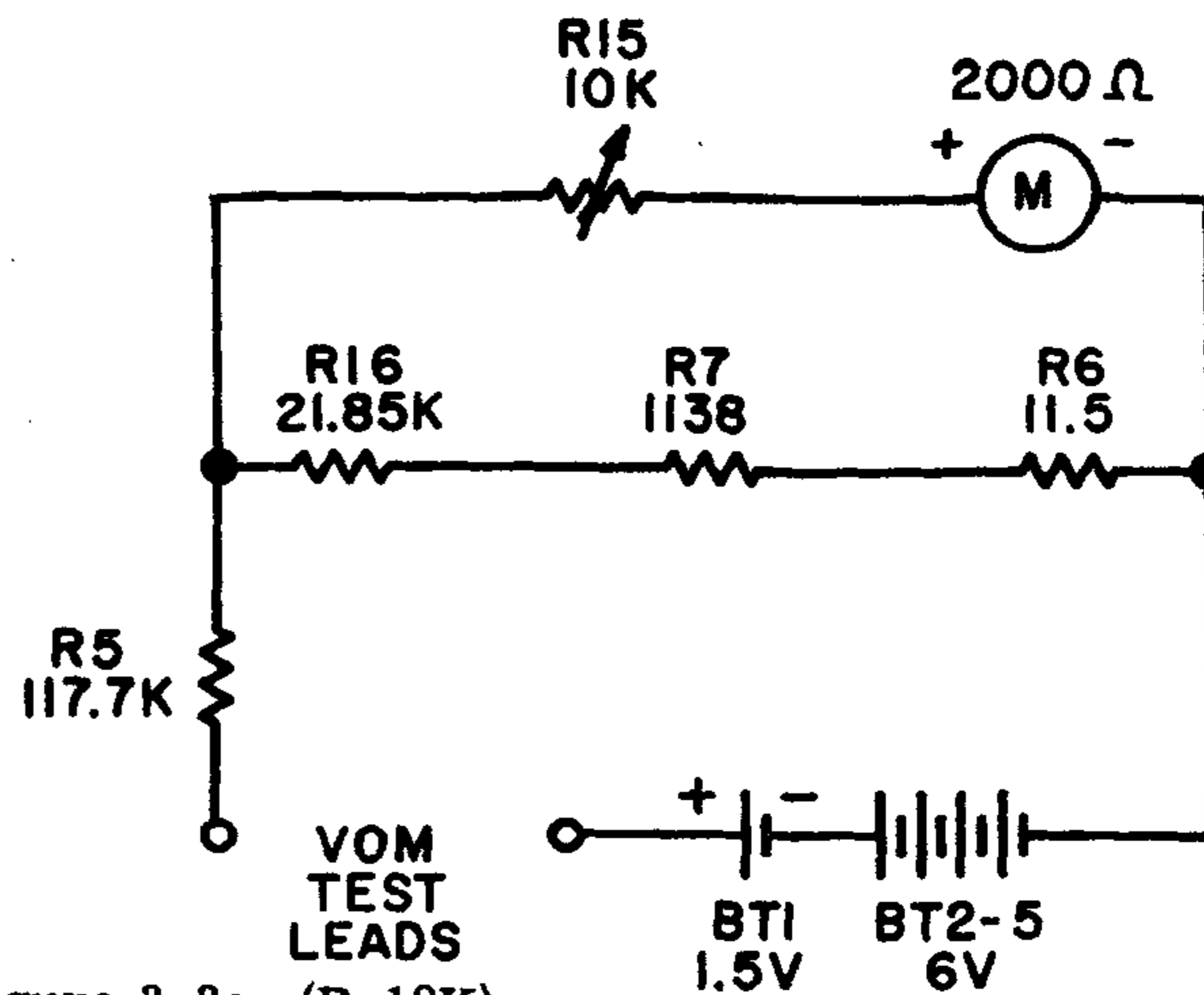

Figure 3-3c. (Rx10K)

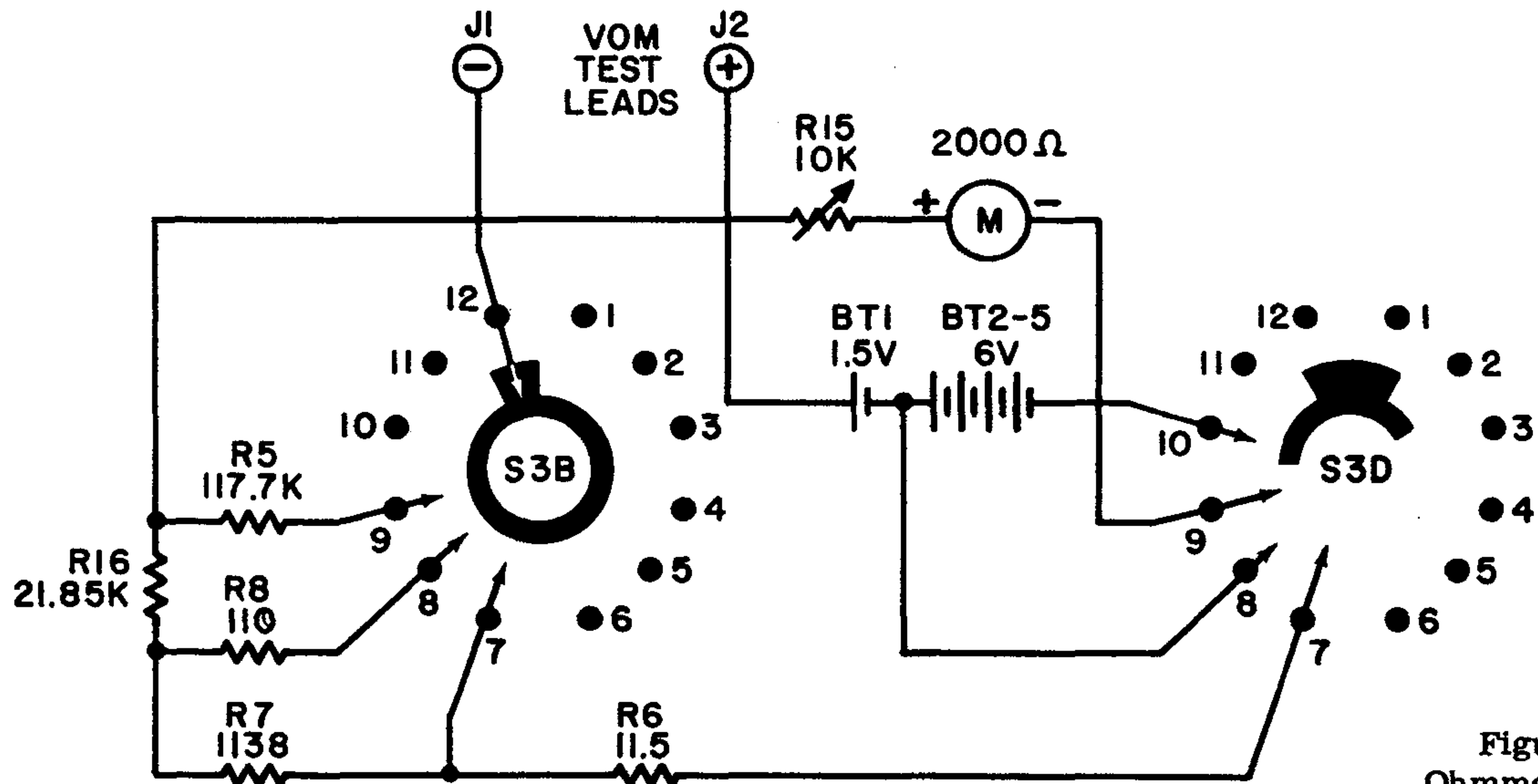

Figure 3-4. Ohmmeter Circuit

The three ohm meter ranges are illustrated in Figure 3-3a, b and c. In each case, the unknown resistor is in series with the supply voltage. There are resistors in series and shunt with the meter movement, chosen so that the meter will read properly on the ohms scale.

### 3-5. ICBO TEST CIRCUIT

This is defined as the leakage between the collector and base when these two elements are reverse biased. In the circuit used in this test, the collector-base junction is biased in the reverse direction, with the emitter lead left open.

emitter. The polarity of this voltage is arranged so that the collector-base junction will be reverse biased. In the circuit used in this test, the base is left disconnected.

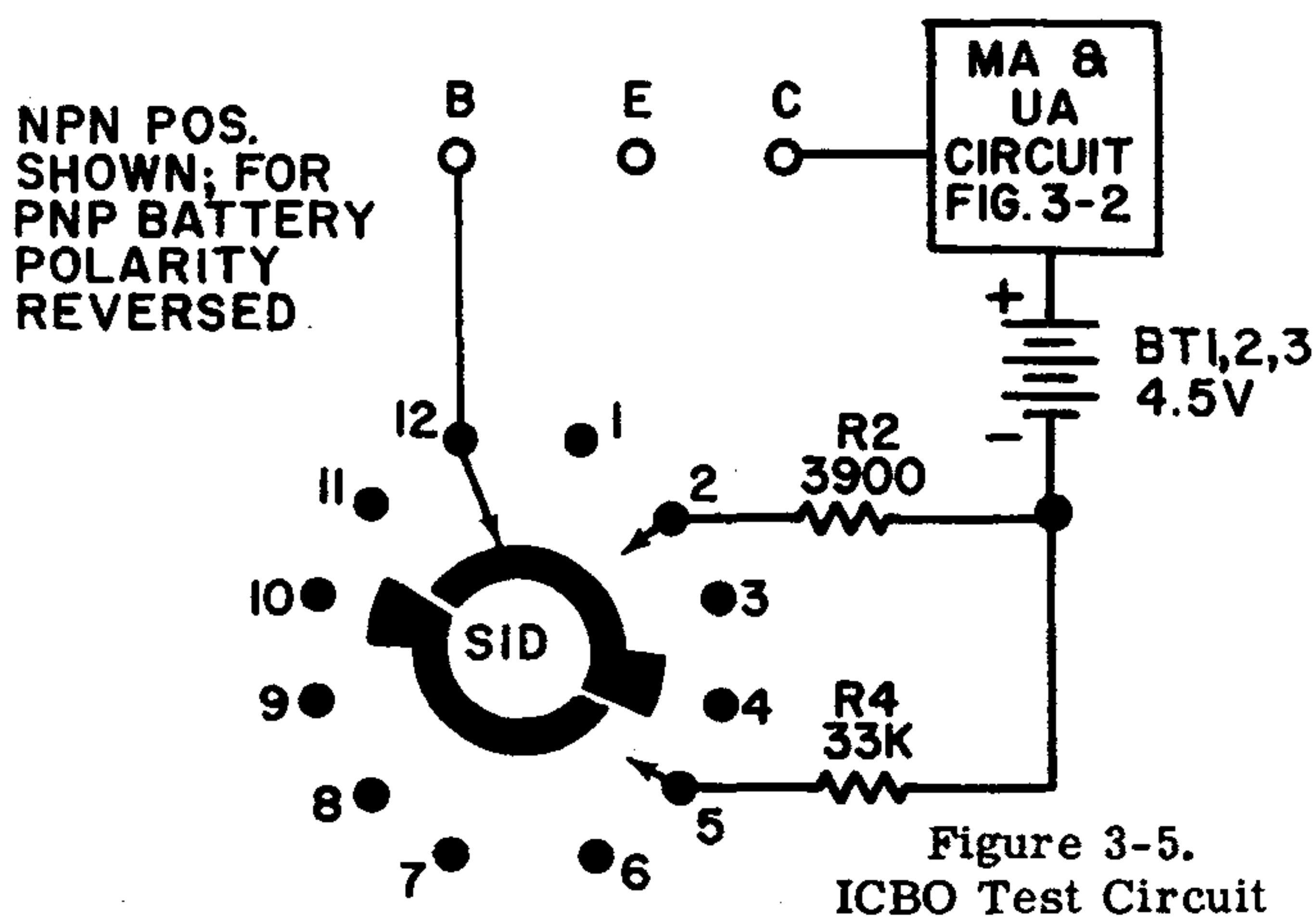

Figure 3-5. ICBO Test Circuit

In the signal ICBO test, the 33K resistor is in series with the base, and in the PWR ICBO test, the 3.9K resistor is in series with the base. These are current-limiting resistors. The a-c current circuit from Figure 3-2 is in series with the collector to measure the leakage current.

### 3-6. ICEO TEST CIRCUIT

This is the collector to emitter leakage current test. The voltage is applied between the collector and

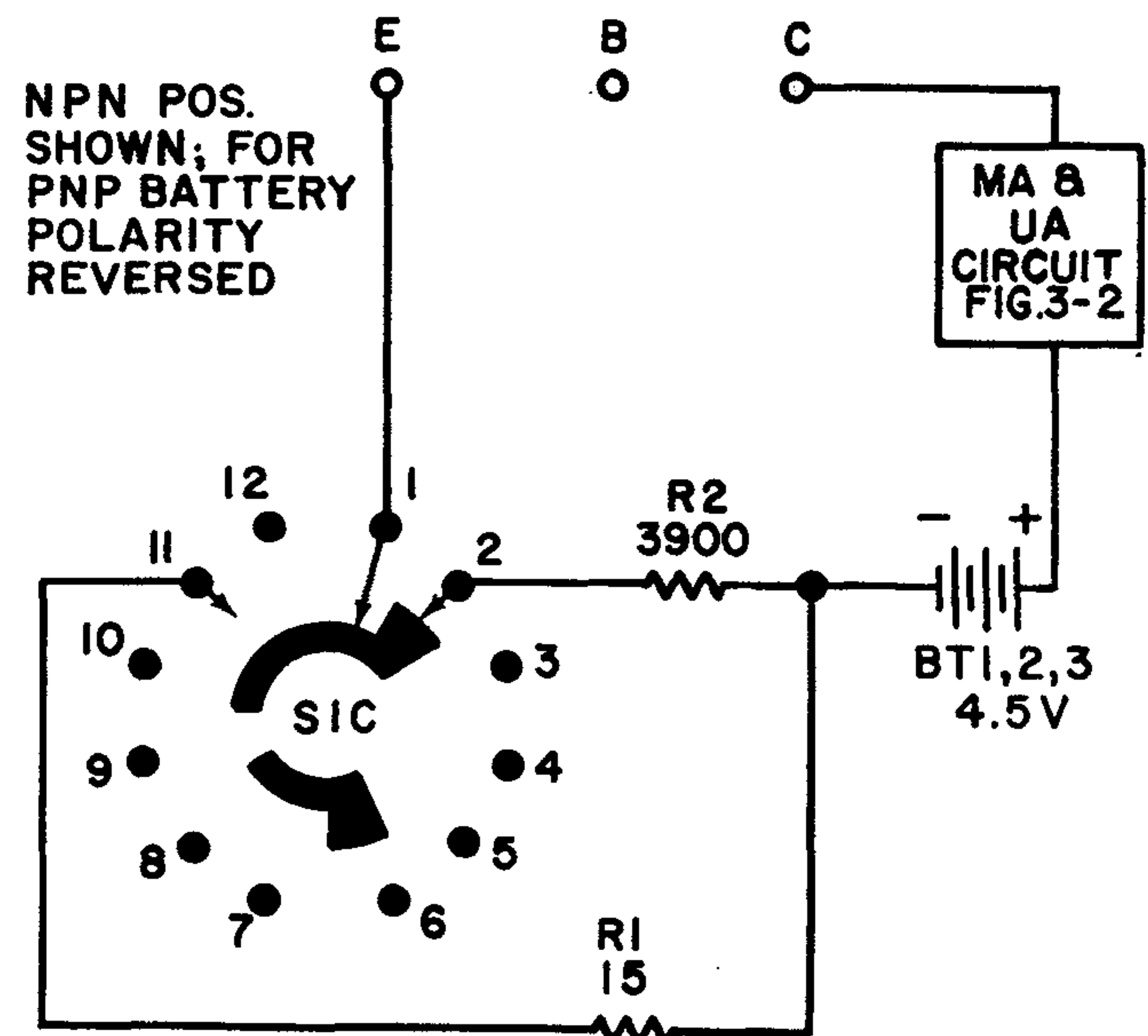

Figure 3-6. ICEO Test Circuit

In the signal ICEO test, the 3.9K resistor is in series with the emitter and in the PWR ICBO test, the 15 ohm resistor is in series with the emitter. These are current-limiting resistors. The a-c current circuit from Figure 3-2 is in series with the collector to measure the leakage current.

### 3-7. BETA TESTS

In this test, the  $\beta$  CAL pot. is used to adjust the base current so that the current in the collector will read 1ma. The meter is then switched into the base circuit, indicating the base current for the 1ma collector current. The ratio of collector to base current is defined as the DC Beta. Since the collector current is 1ma, the DC Beta is equal to the reciprocal of the



base current in ma. For this reason, the base current measurement read on a reciprocal scale is the DC Beta.

The circuit shown in Figure 3-7a. switches the d-c current circuit in Figure 3-2 from the collector circuit in the  $\beta$  CAL position to the base circuit in the Read  $\beta$  position of the TEST switch.

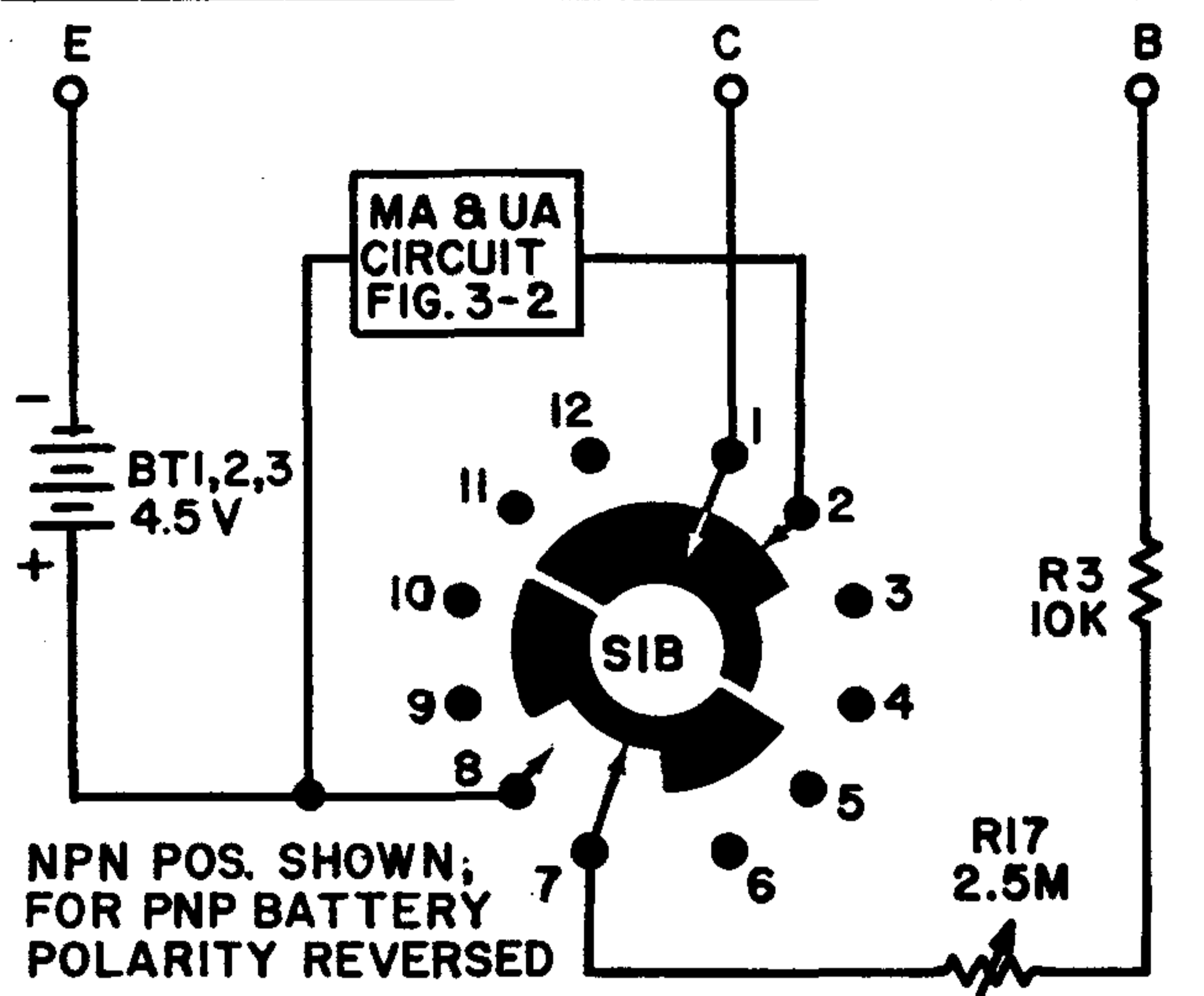

Figure 3-7a. Actual Circuit Switching

In the Simulated AC Beta test, the base currents are read for two values of collector current. The difference of the base currents is divided into the difference of the collector currents to give the AC Beta.

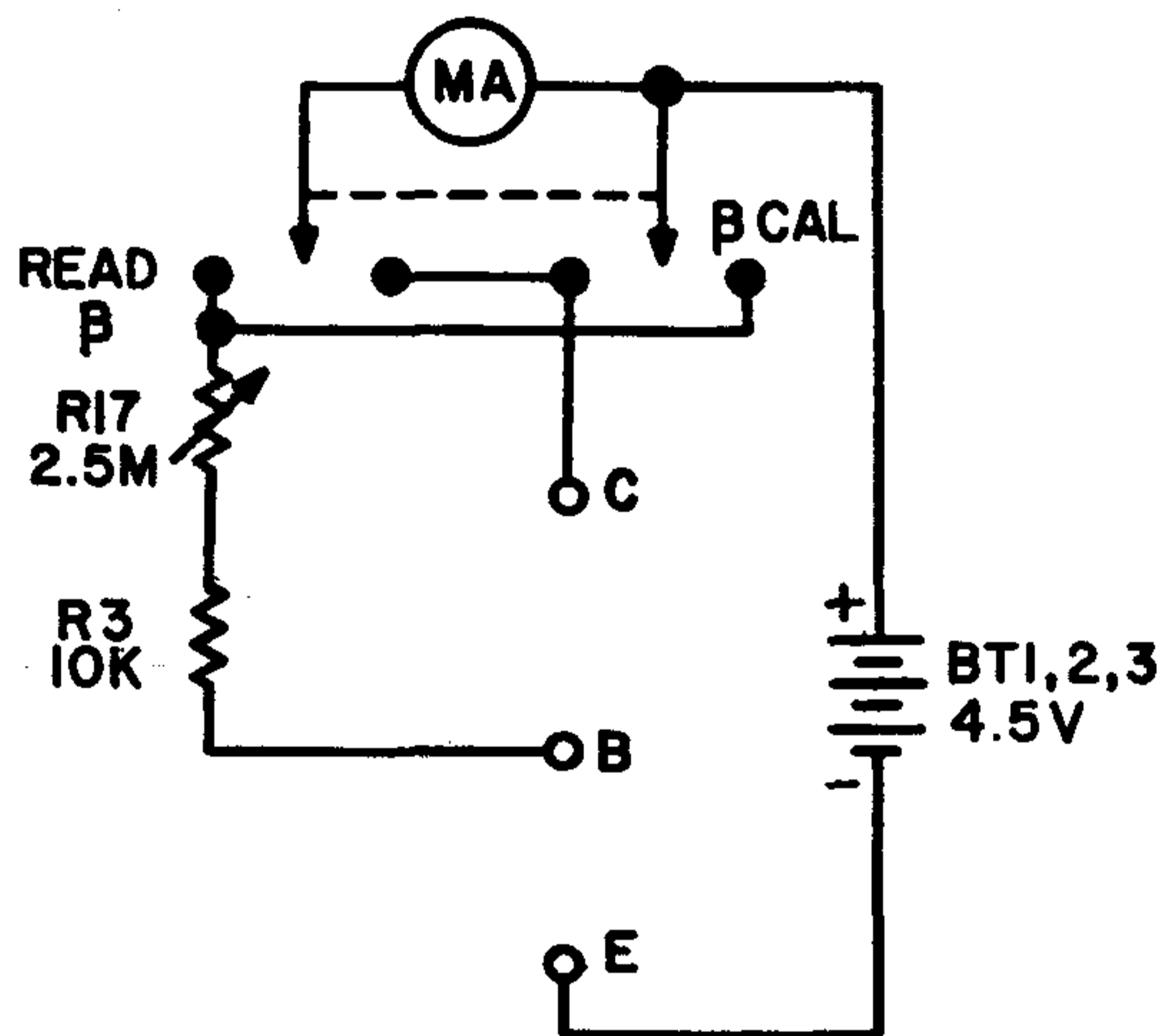

Figure 3-7b. Schematic of Circuit

## SECTION IV. TEST TECHNIQUES

### 4-1. METER RANGES

When in doubt as to the voltage or current to be measured, always use the highest range and then proceed downward until the meter reads somewhere between 1/10 of full scale and full scale.

### 4-2. LEAKAGE TESTS

These tests indicate the defect in the transistor. If ICBO is extremely large, there is a base-collector junction breakdown. Should ICBO be equal to ICEO,

there is an emitter-base junction breakdown. If ICEO is extremely large, punch-through has occurred. In this case transistor is just about completely shorted.

## SECTION V. MAINTENANCE

### 5-1. BATTERY REPLACEMENT

When it is no longer possible to zero the meter on the Rx1 and Rx10 ranges by rotating the ZERO OHMS knob with the test leads shorted, the single, large, 1.5 volt battery should be replaced.

When it is no longer possible to zero the meter on the Rx10K range by rotating the ZERO OHMS knob with the test leads shorted, the 4 small 1.5 volt batteries should be replaced.

Both types of batteries are standard and readily obtainable. The large battery is of the flash light type, and the small batteries are of the pen light type.

NOTE: When replacing batteries, make certain that polarities are observed as shown in the schematic diagram.

The instrument may be taken out of its case by removing the 4 panel screws. Use the drawing, Figure 5-1 when replacing the batteries. Note that only the schematic diagram shows the switches as they are actually constructed. The individual circuit diagrams given in the circuit theory section contain simplified drawings of the switches for the purpose of understanding the operation.

### 5-2. SERVICE

If trouble develops in your instrument which you can not remedy yourself, write to our service department listing all possible indications that might be helpful. List, also, any code numbers in red under the words INSTRUCTION MANUAL on the cover. If desired, you may return the instrument to our factory where it will be placed in operating condition for \$6.00 plus the cost of parts replaced due to their being damaged in the course of construction. NOTE: Before returning this unit, be sure all parts are securely mounted. Attach a tag to the instrument, giving your home address and the trouble with the unit. Pack very carefully in a rugged container, using sufficient packing material (cotton, shredded newspaper, or excelsior), to make the unit completely immovable within the container. The original shipping carton is satisfactory, providing the original inserts are used or sufficient packing material inserted to keep the instrument immovable. Ship by prepaid Railway Express, if possible, to:

Electronic Instrument Co., Inc.  
33-00 Northern Blvd.  
Long Island City 1, N.Y.

Return shipment will be made by express collect. Note that a carrier cannot be held liable for damages in transit if packing IN HIS OPINION, is insufficient.



The following steps refer to figure 5-1.

- ( ) 1. To replace batteries remove the four panel screws and take the unit out of its case (case not shown in figure 5-1.). Replace the four "AA" size (1.5V) batteries observing the polarities as shown in figure 5-1.
- ( ) 2. To replace the "C" size (1.5V) battery remove the meter terminal hardware and battery board. Insert the "C" size battery observing the polarities as shown in figure 5-1.

- ( ) 3. Replace the battery board over the meter terminals. Place one meter flatwasher, one meter lug, one meter flatwasher and one meter hex nut in that sequence over each meter terminal.

NOTE: Make certain that the proper meter lug is placed on its respective meter terminal. Place the lug with the orange wire on the positive (+) terminal and the lug with the 2 purple wires on the minus (-) terminal.

- ( ) 4. Secure the unit in the case using the four screws previously removed.

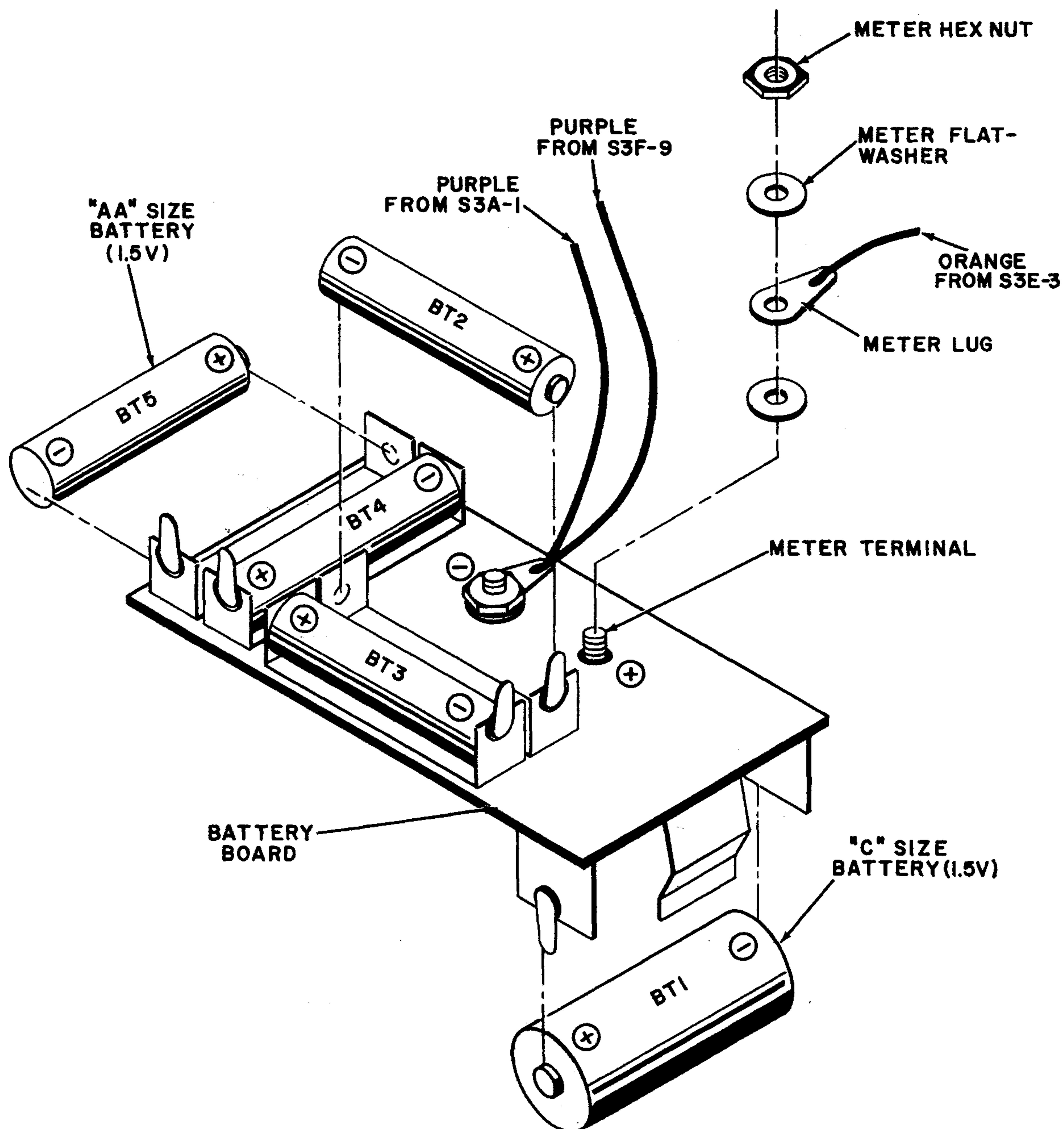

Figure 5-1. Battery Placement



Fig. 5-2. Switching Tables For 680

POS. WAFAER	50V	5V	500MA	50MA	$\beta$ CAL 5MA	$\beta$ x1 500uA	$\beta$ x10 50uA	Rx1	Rx100	Rx10K
S3A	1-12	1-12	1-12	1-12	1-12	1-12	1-12	-	-	-
S3B	-	-	2-12	3-12	4-12	5-12	-	7-12	8-12	9-12
S3C	1-12	2-12	1-3-12	1-2-3-12	1-2-3-12	2-3-6-12	3-12	3-6	3-6	3-6
S3D	-	-	-	-	-	-	-	7-8-9	7-8-9	7-9-10

RANGE SW S3

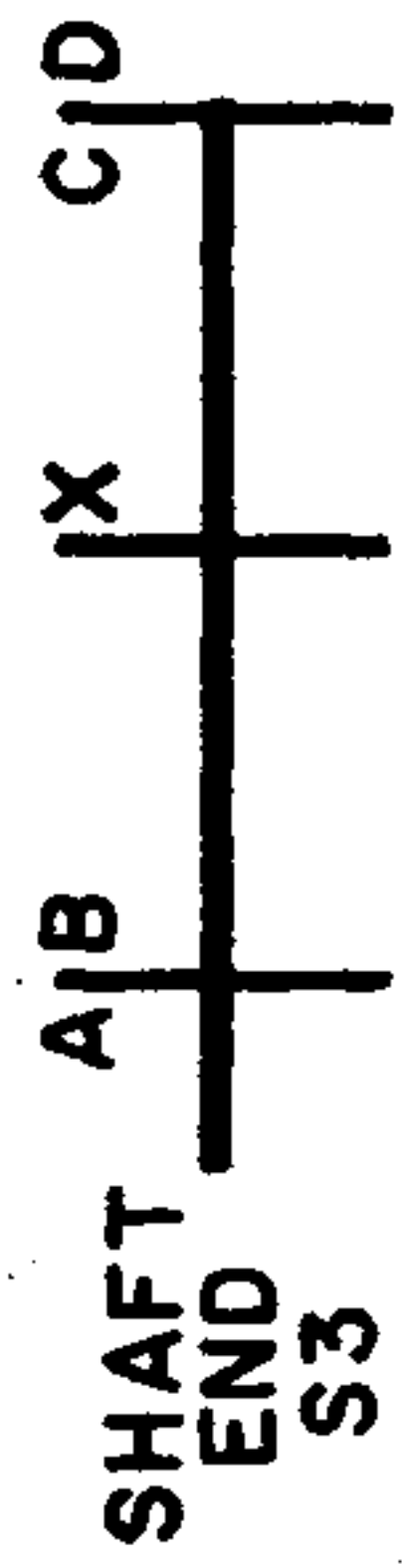

POS. WAFAER	ICEO	ICBO	$\beta$ CAL	READ $\beta$	PWR ICBO	PWR ICEO
S1B	1-2	1-2	1-2, 7-8	1-8, 2-7	1-2	1-2
S1C	1-2	-	1-4	1-4	-	1-11
S1D	-	5-12	8-12	8-12	2-12	-

TEST SW S1

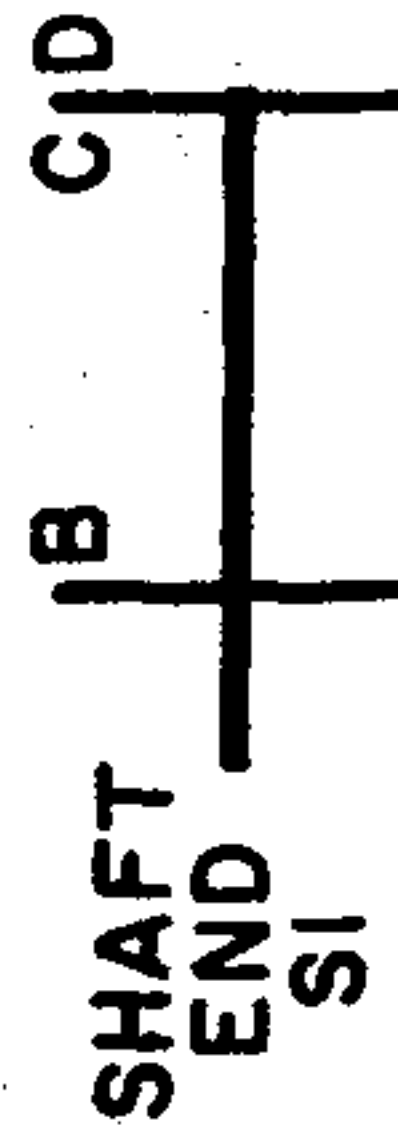

POS. WAFAER	NPN	VOM	PNP
S2A	1-3-12	1-4-12, 10-11	1-5
S2B	2-5, 7-9	2-6	2-3-7, 9-12

MODE SW S2

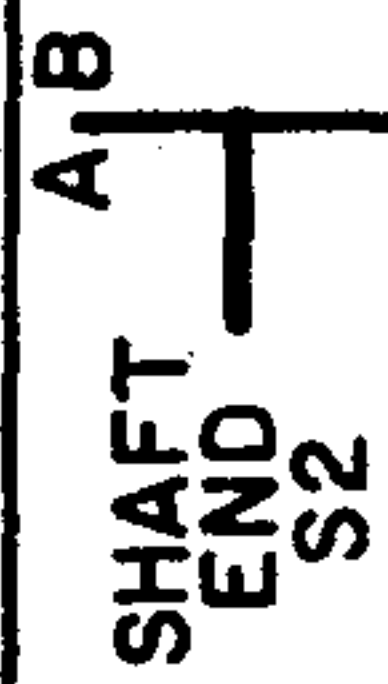



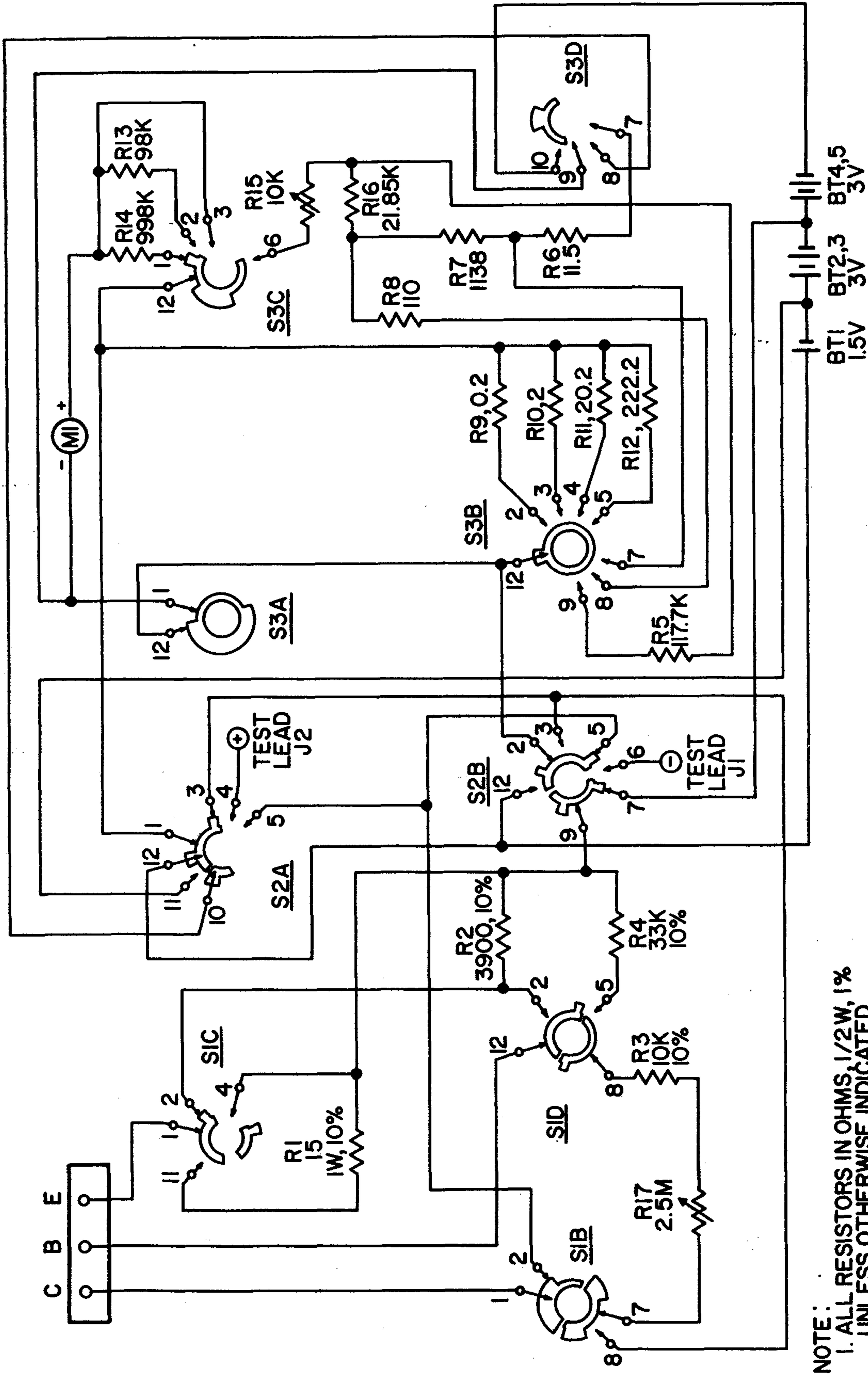

NOTE:

1. ALL RESISTORS IN OHMS, 1/2 W, 1% UNLESS OTHERWISE INDICATED.
2. M = MEGOHMS (1,000,000)
3. K = KILOHMS (1,000)
4. ALL SWITCHES SHOWN AT FURTHEST CCW POSITIONS ON PANEL, SEE SWITCHING TABLES FOR CONTACTS MADE AT EACH POSITION.

Figure 5-2. Schematic Diagram for 680



## SECTION VI. REPLACEMENT PARTS LIST

SYM.#	STOCK#	AM'T.	DESCRIPTION
BT1	56003	1	battery, size "C"
BT2,3,4,5	56002	4	battery, size "AA"
J1,J2	50004	2	jack, banana
M1	71006	1	meter, 50uA
P1, P2	51005	2	plugs, banana
R1	10870	1	resistor, 15 ohm, 1W, 10% (brown,green,black,silver)
R2	10450	1	resistor, 3.9K ohm, 1/2W, 10% (orange,white,red,silver)
R3	10400	1	resistor, 10K ohm, 1/2W, 10% (brown,black,orange,silver)
R4	10426	1	resistor, 33K ohm, 1/2W, 10% (orange,orange,orange,silver)
R5	11024	1	resistor, 117.7K ohm, 1/2W, 1%
R6	11001	1	resistor, 11.5 ohm, 1/2W, 1%
R7	11010	1	resistor, 1138 ohm, 1/2W, 1%
R8	11006	1	resistor, 110 ohm, 1/2W, 1%
R9	13005	1	resistor, 0.2 ohm, 1/2W, 1%
R10	13002	1	resistor, 2 ohm, 1/2W, 1%
R11	11082	1	resistor, 20.2 ohm, 1/2W, 1%
R12	11083	1	resistor, 222.2 ohm, 1/2W, 1%
R13	11084	1	resistor, 98K ohm, 1/2W, 1%
R14	11085	1	resistor, 998K ohm, 1/2W, 1%
R15,R17	18087	1	potentiometer, dual, 10K ohm, 2.5 Megohm
R16	11019	1	resistor, 21.85K ohm, 1/2W, 1%
S1	60097	1	switch, rotary, 2 wafer, 6 position
S2	60098	1	switch, rotary, 1 wafer, 3 position
S3	60099	1	switch, rotary, 3 wafer, 10 position
TB1	54518	1	terminal board
XB1	56519	1	bracket, battery, size "C"
XB2-3, 4-5	56509	2	bracket, battery, size "AA"
XQ1	97043	1	socket, transistor
	40001	4	nut, hex, 3/8"
	40004	2	nut, hex, No. 2-56
	40007	6	nut, hex, No. 4-40
	40044	2	nut, insert, No. 10-32
	41016	10	screw, No. 4-40 x 1/4, binding head
	41106	2	screw, No. 2-56 x 3/8, binding head
	41112	2	screw, No. 10-32 x 5/16, black
	42000	4	washer, lock, 3/8"
	42001	4	washer, flat, 3/8"
	42007	6	washer, lock, No. 4
	42025	2	washer, fiber shoulder, 1/4"
	42053	2	washer, lock, No. 2
	43003	2	lug, solder, 1/4"
	45000	2	eyelet, brass
	46014	3	grommet, rubber, 1/8"
	51505	5	clip, alligator
	53001	1	knob, small
	53006	3	knob, large
	58400	length	cable, kinkless, black
	58404	length	cable, kinkless, red
	58426	length	cable, kinkless, yellow
	80105	1	panel
	87003	1	handle, leather
	88108	1	cabinet
	89672	2	insulator for alligator clip, black
	89673	2	insulator for alligator clip, red
	89674	1	insulator for alligator clip, yellow
	66105	1	manual of instructions (wired)
	66358	1	manual of instructions (kit)